

Assessment of Distribution System Reliability and Possible Mitigation by Using Reclosers and Disconnectors: The Case of Cotobie Distribution Station

Seada Hussen¹, Dr. Kemal Ibrahim²

^{1,2}Addis Ababa Science and Technology University, Addis Ababa, Ethiopia
Email: ¹seada.hussen@aastu.edu.et, ²kemibr2003@gmail.com

Abstract - The distribution system reliability assessment deals with availability and quality of power supply at each customer service entrance. This paper focuses the assessment of power distribution reliability of Addis Ababa city which is connected from Cotobie distribution substation and the possibility of using smart reclosers and disconnectors to mitigate the urgent and pressing power interruption problems. Depending on the assessment result Cotobie distribution substation has reliability indices such as average frequency of interruption is 133.37 interruptions per year per customer and the average interruption duration is 187.31 hours per year per customer. This value shows the substation has greater reliability problems and the substation does not meet the requirements set by the regulatory body that is Ethiopian Electric Authority (EEA). In this paper, the reliability is improved to 22.27 interruptions per year per customer average frequency of interruption and the average interruption duration is 31.274 hours per year per customer. It can also improve above this value depending on the segment and recloser number. The designed system is simulated using WindMil software that is used to analyze the reliability of the overall system. The simulation of the designed model shows that the application of smart reclosers and disconnector coordination can improve the reliability from 50% up to 83.3%.

Key Words - Reliability, Cotobie distribution substation, Smart recloser, Disconnector, reliability Indices

I. INTRODUCTION

Sub-transmission poles, power transformers, 33 kV lines, 15 kV lines, distribution transformers, LV (low voltage) lines, etc., make up the power distribution grid. Inside the system, distribution substations track and change circuits. Currently, Ethiopian Electric Power has 400 kV, 230 kV, 132 kV primary transmission systems and 66 kV, 45 kV as sub-transmission system and 33 kV and 15 kV as the distribution system. The case study (Cotobie distribution substation) is a radial distribution system with two 230/132/15 kV transformers and nine feeders, but one feeder is on construction now (see Figure 1).

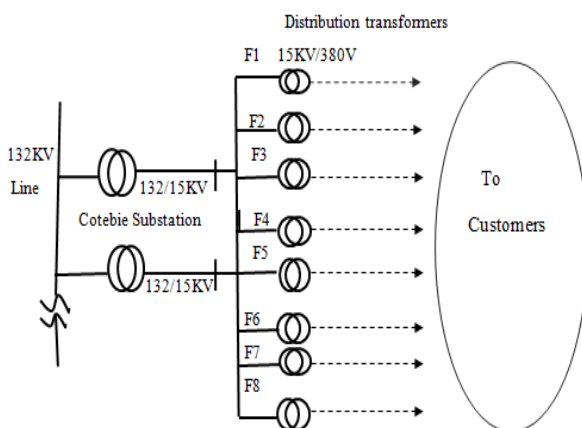

Figure 1: Cotobie distribution substation single line diagram

II. LITERATURE SURVEY

The reliable power supply is of great importance in the electrical power system network for residential, commercial, industrial with the purpose of economic growth for a given nation or place. Many researchers have been developed with different reliability measures and improvement techniques for the last many years. Somporn S. [1] introduced network reconfiguration for reliability worth enhancement in the distribution system by simulated annealing. T. K. VRANA, et al. [2] discussed different aspects of reliability, described details regarding modeling, and provided examples of reliability assessment techniques, and it was also discussed the concept of reliability worth. K Alekhya et al. [3] presented an increasing interest in the qualitative assessment of power system reliability worth and its application to a cost-benefit evaluation in power system planning; it also introduced a feeder automation system using the concept of optimal placement of switches. Bowen H. Et al. [4] presented about reliability evaluation of distribution systems by considering demand response, the system studies conducted on modified RBTS lead to Time-of-use pricing changes in the demand profile, which results in a smoother load curve and better reliability performance. A very simple analytical method has been implemented for the system analysis presented by Sudip M. et al. [5]. A hybrid methodology for finding optimal DG connection specifications is proposed to operate the power system with

minimal power loss and highly reliable power transmission and distribution based on the combination of the neural network and genetic algorithm approach presented by S.Chandrashekhar R. Et al. [6].

V.Ashok, et al. [7] Presented the power system's reliability can be calculated by different reliability indices; the performance can be improved by system planning and analysis studies to provide switches, sectionalizes and other protective devices at appropriate places. Z. Kovac et al. [8] presented the way of modeling a subsystem of the power system from the power supply interruption consumer's point; results of reliability assessment indicate significant differences of products depending on the modeling and understanding of the input data. L. Gao et al. [9] presented a new method based on Bayesian Networks is introduced for reliability analysis of distribution systems with distributed generation, the technique permits not only computing the reliability indices of a distribution system but also presenting the effect of each component or some components on the system reliability. Due to the quick operation of reclosers, some power quality issues may happen in the system. In this paper, a Monte Carlo based method has been proposed for setting reclosers. This was presented by R. N. Azari [10]. Bill Glennon et al. [11] this paper addressed the automation of distribution systems to reconfigure the network in the case of system disturbances and changes in loads; it was presented in two times in Saudi Arabia in 2012 and in the USA by 2018.

III. RELIABILITY INDICES

This is a necessary condition for having indices that expresses a system failure event on a probability and frequency basis. There are three primary indices: failure rate (λ), outage duration (r) and average annual outage time (U), which permits the measurement of reliability at each load point to be quantified and allow subsidiary indices such as the customer interruption indices to be determined[16].

Reliability indices typically consider such aspects as:

- The number of customers;
- The connected load;
- The duration of the interruption measured in seconds, minutes, hours, or days;
- The amount of power (kVA) interrupted; and
- The frequency of interruptions.

Distribution System Reliability Indices: The system indices commonly used by electricity supply utilities are divided in to two categories: [1, 11, 12, 13,14, 15, 16, 18, 19,20].

A. Customer Based Indices

1. System Average Interruption Frequency Index (SAIFI): The average number of interruptions (sustained) per utility customer during the analysis period. This is simply the number of customer interruptions per year divided by the total customers on the system.

$$SAIFI = \frac{\text{Total number of customers interruption}}{\text{Total number of customer served}} = \frac{\sum_i \lambda_i N_i}{\sum_i N_i} \quad (1)$$

2. System Average Interruption Duration Index (SAIDI):- is the average duration during the analysis time of all interruptions per utility user (usually annually). The result of the number of customers interrupted and the corresponding period is measured and known as customer minutes for each interruption point. The total customer minutes interrupted was added to the total number of faults in the period under examination and divided by the total number of customers served in the device or region under assessment.

$$SAIDI = \frac{\text{Sum of customer interruption duration}}{\text{Total number of customer}} = \frac{\sum_i U_i N_i}{\sum_i N_i} \quad (2)$$

3. Customer Average Interruption Frequency Index (CAIFI): For all customers experiencing prolonged interruptions, this index gives the average frequency of sustained interruptions. The customer is counted once regardless of the number of times interrupted for this calculation.

$$CAIFI = \frac{\text{Total number of customers interruptions}}{\text{Total number of customer affected}} = \frac{\sum_i N_i}{\sum_i N_o} \quad (3)$$

4. Customer Average Interruption Duration Index (CAIDI): is the average time needed to restore service to the average customer per sustained interruption. It is the sum of customer interruption durations divided by the total number of customer interruptions.

$$CAIDI = \frac{\text{Sum of customer interruption durations}}{\text{Total number of customers interruption}} \\ = \frac{\sum_i U_i N_i}{\sum_i \lambda_i N_i} \quad (4)$$

5. Average Service Availability Index (ASAI): This index reflects the fraction of the time (often as a percentage given by a customer for a year or a specified reporting period..

$$ASAI = \frac{\text{Customer hours of available service}}{\text{Customer hours demanded}} \\ = \frac{\sum_i N_i * 8760 - \sum_i U_i N_i}{\sum_i N_i * 8760} \quad (5)$$

6. Average Service Unavailability Index (ASUI): This index is the complementary value to the average service availability index (ASAI).

$$ASUI = 1 - ASAI \\ = \frac{\text{Customer hours of unavailable service}}{\text{Customer hours demanded}} \\ = \frac{\sum_i U_i N_i}{\sum_i N_i * 8760} \quad (6)$$

B. Load or Energy Based Indices

1. Energy Not Supplied Index (ENS): This index represents the total energy not supplied by the system. And it is given by

$$ENS = L_a(i)U_i \quad (7)$$

Where, $L_a(i)$ is the average load given by:

$$L_a(i) = L_p(i) * L_F(i) = \frac{L_d(i)}{t} \quad (8)$$

L_p Is peak demand, L_F The load factor is the load factor and in the time of interest t , E_d is the total energy needed t .

2. Average Energy Not Supplied Index (AENS): This index represents the system's average energy not supplied.

$$AENS = \frac{\text{Total energy not supplied}}{\text{Total number of customer served}} \\ = \frac{\sum_i L_a(i)U_i}{\sum_i N_i} \quad (9)$$

3. Average Customer Curtailment Index (ACCI): This index represents the total energy not supplied per affected customer by the system.

$$ACCI = \frac{\text{Total energy not supplied}}{\text{Total number of customer affected}} \\ = \frac{\sum_i L_a U_i}{\sum_i N_o} \quad (10)$$

Where: $L_a(i)$ is the average load and N_o is the number of customers affected.

These indices can be calculated using the basic load point indices. That is, Average Failure Rate, (A), the Average Outage Duration, (r) and the Annual Outage Duration, (μ) [17].

IV. RELIABILITY IMPROVEMENT METHODS

There are different improvement methods such as network reconfiguration, using distribution generators, component aging and using different protection devices and combination of protection devices. Reliability improvement methods used in this thesis are the combination of protection devices combined by recloser and disconnectors. This method is used for clearing permanent or temporary fault before the source side device interrupt, Outage restricted, improve voltage profile and decrease loading existing electric equipment, less operation cost.

A. Recloser

To interrupt both load and fault current, a distribution recloser is built. It is also intended to repeatedly reclose the fault in a predefined sequence in an attempt to clear the spot according to its term.

B. Disconnecter

Usually, these are air brake systems that are not typically equipped for automatic operation and are for local operation (and often remote). These devices are useful for the temporary manual repair of fault lines, where it can be beneficial to manually reconfigure a line to restore as many of the segments as possible after a fault if many are used.

V. BASIC DATA'S OF COTOBIE DISTRIBUTION SUBSTATION

There are two transformers in the Cotobie distribution substation with voltage level 132/15KV and a capacity of 31.5MVA for each. The Cotobie distribution substations' data are total number of distribution transformers, total number of customers, medium and low voltage line length, Conductor size of each feeder, average and peak demand, and soon. Some of them are shown in Table I.

The total number of customers supplied from the Cotobie distribution substation is 27,210: domestic,

commercial, industrial and, residential; from this total number, 16,605 customers are post-paid customers and 10,605 customers are pre-paid customers. And there are 309 distribution transformers to supply the total customers. They

are using ABC (95 and 150mm²), AAC (25, 50 and 90mm²) and, underground ASCR (240mm²) type cables by different distances.

TABLE I
BASIC DATA'S OF COTEBIE DISTRIBUTION SUBSTATION

Feeders	Total number of transformers	Total transformer capacity(MVA)	Load points	Total number of customers	MV line length (Km)	LV line length (Km)	Average demand (MW)	Peak load (MW)	Remark
F1	2	0.63	2	2	2	2	0.925	1.325	Dairy Farm
F2	19	3.75	5	2,476	5	45	3.450	6.000	Kebena
F3	38	7.705	5	3,052	17.3	66.3	5.3125	9.375	Cotobie
F4	41	9.645	8	3,240	25.2	90	5.608	9.433	Bole
F5	48	9.915	7	3,358	10	61	4.008	6.583	Gurd Shola
F6	60	18.41	8	5,690	18.3	78	5.307	8.900	CMC
F7	55	14.255	8	5,225	16	63	5.050	8.257	Tsehay Real-estate
F8	46	6.055	7	4,167	12	42.2	4.683	7.344	Wosen
Total	309	70.365	50	27,210	112	447.5			

Fault Statics (Interruption): Interruptions in Cotobie distribution substation are classified as planned and unplanned Outage.

Planned outages: are happened for maintenances, transformer tripping, for changing of the new meter, for a tasting of fire protection circuits, for safety and soon, such as operational and request interruptions.

Unplanned outages: such as Permanent Short circuit (PSC), Permanent Earth Fault (PEF), Transient Earth fault (TEF),

Transient Short circuit (TSC), Under Frequency (UF), Total (blackout) and, so on.

Fault statistics data comprises the daily interruptions of power, duration and cause of each interruption. The planned and unplanned outage duration (hr.) and frequency of planned and unplanned outage yearly data are analyzed in Table II. The data helps us to quantitatively describe the reliability of the network with standard performance indicators and compare with standard values. Note that in table II Dur. Refers to duration and Int. refers to interruption.

TABLE II
FAULT STATICS DATA OF COTOBIE DISTRIBUTION SUBSTATION 2017 AND 2018

Feeders	Total 2016/17 Dur. (Hr.)	Total 2017/18 Dur. (Hr.)	Average Dur. (Hr.)	Total 2016/17 (Int. /yr.)	Total 2017/18 (Int. /yr.)	Average Freq. (Int. /yr.)
F1	37.913	126.78	82.3465	69	43	56
F2	156.767	220.46	188.61	15	141	78
F3	219.783	303.14	261.46	103	266	185
F4	172.803	283.76	228.28	156	280	218
F5	69.817	158.86	114.338	50	138	94
F6	87.867	210.73	149.3	34	225	130
F7	74.500	233.39	153.945	36	210	123
F8	88.610	382.05	235.33	51	173	112

VI. RELIABILITY INDICES CALCULATION OF THE EXISTING NETWORK

Reliability indices are calculated by using equations 1–10 and using Table I and II; the average indices value of 2016/17 and

2017/18 are shown in Table III. This calculation is used to conclude the system is reliable or not. Reliability indices for each feeder and on the network are shown in Table III.

TABLE III

RELIABILITY INDICES OF AVERAGE 2016/17 AND 2017/18

Feeders	SAIFI	SAIDI	CAIDI	ASAI	ASUI	ENS	AENS
F1	56	82.35	1.470	0.9906	0.0094	76.170	38.085
F2	78	188.61	2.420	0.9790	0.0210	650.700	0.263
F3	185	261.46	1.413	0.9702	0.0298	1389.006	0.455
F4	218	228.28	1.047	0.9739	0.0261	1280.194	0.224
F5	94	114.34	1.216	0.9870	0.0130	458.266	0.087
F6	130	149.30	1.148	0.9830	0.0170	792.335	0.235
F7	123	153.94	1.251	0.9825	0.0175	777.422	0.239
F8	112	235.33	2.260	0.9732	0.0268	1102.050	0.264
System	133.37	187.31	1.4045	0.9786	0.0214	6526.168	0.239

This fault statistics data shows the reliability of the network is far behind standards shown in Table IV; it shows the reliability indices (SAIFI and SAIDI) of best-experienced

countries, including that of the Ethiopian Electric Agency (EEA) and average yearly fault statics of Cotobie distribution substation is shown in Table IV.

TABLE IV
RELIABILITY INDICES STANDARDS OF DIFFERENT COUNTRIES [17]

Country	SAIFI (int/yr.cust)	SAIDI (h/yr.cust)
United States	1.5	4.0
Australia	0.9	1.2
Denmark	0.5	0.4
France	1.0	1.03
German	0.5	0.383
Italy	2.2	0.967
Netherlands	0.3	0.55
Spain	2.2	1.73
United Kingdom	0.8	1.5
Ethiopia	20.0	25.0
Cotobie distribution substation	F1	56
	F2	78
	F3	185
	F4	218
	F5	94
	F6	130
	F7	123
	F8	112
	Total system	133.37

A. Loss of Revenue due to Power Interruption in Cotobie distribution Substation:

Depending on EEPCO'S electricity tariff (Birr/kwh) the cost of energy not supplied due to interruption for Cotobie distribution Substation is calculated using the formula,

Considering an average electricity price of 0.5345 Birr/kWh, the average energy not supplied and the average energy expense not supplied by the Cotobie outgoing feeder due to a one-month power interruption was estimated and tabulated in Table V.

$$\text{Cost of Energy} = \text{power} * \text{time} * \text{tariff for electricity} \quad (11)$$

TABLE V
AVERAGE COST OF SINGLE MONTH ENS FOR COTOBIE OUTGOING FEEDERS

Feeders	Peak Load(MW)	Duration of interruption (Hr.)	ENS(MWh)	Cost of energy not supplied(Birr)
F1	1.325	28.06	37.1795	19,872.44
F2	6.000	23.41	140.4600	75,075.87
F3	9.375	32.92	308.6250	164,960.06
F4	9.433	54.50	514.0985	274,785.65
F5	6.583	20.85	137.2555	73,363.06
F6	8.900	55.27	491.9030	262,922.15
F7	8.257	43.78	361.4914	193,217.15
F8	7.344	34.83	255.7915	136,720.56
Total	57.217	293.61	2,246.8044	1,200,916.95

As shown in the table, 2,246.8044 MWh and 1,200,916.95 Birr respectively are the overall average energy not supplied and the average cost of energy not supplied due to power interruption for one month at Cotobie outgoing feeders. For the substation outgoing feeders, the overall average cost of energy supplied not attributable to power interruption per year is $12 * 1200916.95 = 14.411$ million Birr.

B. Summary of the Existing Feeder

1. As per the Ethiopian Electrical Agency (EEA)'s standard, SAIFI should not exceed 20 interruptions per customer per year [17], but in the Cotobie distribution substation (Table III), its average value 127 int./yr./cust. This indicates that there is a serious reliability problem in the present Cotobie distribution substation.
2. The device's SAIDI is 1762hr./yr./custom./custom. (Table III). This also means that the current Cotobie delivery substation has a great reliability problem. The SAIDI value should not exceed 25 hours per client per year as per (EEA)[17].
3. ENS of the overall system was 26,961.6MWh. It indicates the un-served or unsold energy of each feeder. This creates 14.411 million Birr per year amount of money wastage for the country (Table IV).

VII. SIMULATION STUDIES AND RESULT ANALYSIS

Design with smart protection devices makes the system smart. This smart grid implementation used to enhance present grid reliability. Those protection devices are smart reclosers, sectionalizers, disconnectors, circuit breakers, and soon. To improve the distribution systems' power reliability, the feeders are sectionalized using smart reclosers and

disconnectors into smaller sections. In addition to that, respective to nearby feeders (feeder 1 and 2, feeder 3 and 4, feeder 5 and 6, feeder 7 and 8) have been connected by using tie reclosers. The reclosers are used to improve the reliability problems and the disconnectors are designed for each load point used for maintenance of the system. Figure 2 shows the sample design of two feeders with reclosers (R1 and R2 normally closed, and R3 normally open tie recloser) and D is the disconnector.

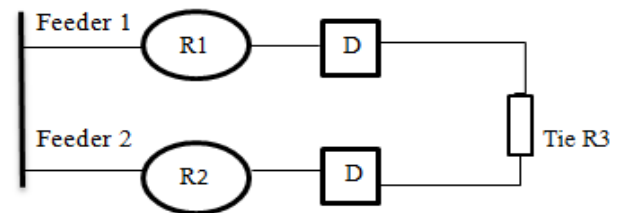

Figure 2: Single line diagram of sectionalized feeders with reclosers and disconnectors

The redesigned models are designed using four options. These are:

1. The model designed by segmenting each feeder into two parts,
2. The model designed by segmenting each feeder into three parts, and
3. The model was designed by segmenting each feeder into four parts.
4. The model designed by segmenting each feeder into six parts

NB: The smart grid design using smart reclosers for feeder one is done only with two segments because it is a dedicated line for two customers only, so it is not possible to segment the feeder by the number of customers. But it can loop with feeder two.

Table VI shows the summary of each feeder interruption improvement using smart reclosers and segmenting the feeders into two, three, four, and six parts. Note that in Table VI, Freq-

Int is Frequency of interruption (interruptions/year), and Int-Dur is Duration of Interruptions (hours/year).

TABLE VI
INTERRUPTIONS IMPROVEMENTS USING SMART RECLOSERS

Feeder	Present Grid		Future Grid								
			Number of Segments								
	Freq-Int	Int-Dur	2		3		4		6		
		Freq-Int	Int-Dur	Freq-Int	Int-Dur	Freq-Int	Int-Dur	Freq-Int	Int-Dur	Freq-Int	Int-Dur
1	56	82.35	28.0	41.175	-	-	-	-	-	-	-
2	78	188.61	39.0	94.305	26.00	62.94	19.50	47.15	13.00	31.435	
3	185	261.46	92.5	130.730	61.67	87.14	46.25	65.36	30.83	43.576	
4	218	228.28	109.0	114.140	72.67	76.09	54.50	57.07	36.33	38.046	
5	94	114.34	47.0	57.170	31.33	38.10	23.50	28.58	15.67	19.056	
6	130	149.30	65.0	74.650	43.33	49.74	32.50	37.32	21.67	24.883	
7	123	153.94	61.5	79.970	41.00	51.31	30.75	38.48	20.50	25.656	
8	112	235.33	56.0	117.665	37.33	78.44	28.00	58.83	18.67	39.222	

A. Reliability Indices of the Designed System

Reliability indices of the designed system are calculated by using equations 1 – 10 and using Table I and VI. It is simulated by using windmill student version 8.7.30.3521 software and analyzed table VII, VIII, IX, and X.

TABLE VII
RELIABILITY INDICES RESULTED FROM SEGMENTING EACH FEEDER INTO TWO PARTS

Feeders	SAIFI	SAIDI	CAIDI	ASAI	ASUI	ENS	AENS
F1	28.0	41.175	1.470	0.9953	0.0047	38.09	19.021
F2	39.0	94.305	2.420	0.9892	0.0108	325.35	0.132
F3	92.5	130.730	1.413	0.9851	0.0149	694.57	0.222
F4	109.0	114.140	1.047	0.9870	0.0130	640.09	0.112
F5	47.0	57.170	1.216	0.9935	0.0065	229.14	0.043
F6	65.0	74.650	1.148	0.9915	0.0085	396.17	0.117
F7	61.5	79.970	1.251	0.9912	0.0088	403.84	0.119
F8	56.0	117.665	2.260	0.9856	0.0144	551.02	0.132
System	66.7	93.656	1.4045	0.9893	0.0107	3263.08	0.120

TABLE VII:
RELIABILITY INDICES RESULTED FROM SEGMENTING EACH FEEDER INTO THREE PARTS

Feeders	SAIFI	SAIDI	CAIDI	ASAI	ASUI	ENS	AENS
F1	28.00	41.16	1.470	0.9953	0.0047	38.09	19.021
F2	26.00	62.94	2.420	0.9928	0.0072	216.90	0.088
F3	61.67	87.15	1.413	0.9901	0.0099	463.05	0.148
F4	72.67	76.09	1.047	0.9913	0.0087	426.73	0.074
F5	31.33	38.10	1.216	0.9957	0.0043	152.76	0.028
F6	43.33	49.74	1.148	0.9943	0.0057	264.11	0.078
F7	41.00	51.31	1.251	0.9941	0.0059	269.23	0.079
F8	37.33	78.44	2.260	0.9905	0.0095	367.35	0.088
System	44.45	62.44	1.4045	0.9929	0.0071	2198.22	0.081

TABLE IX:
RELIABILITY INDICES RESULTED FROM SEGMENTING EACH FEEDER INTO FOUR PARTS

Feeders	SAIFI	SAIDI	CAIDI	ASAI	ASUI	ENS	AENS
F1	28.00	41.16	1.470	0.9953	0.0047	38.090	19,021
F2	19.50	47.15	2.420	0.9892	0.0108	162.675	0.066
F3	46.25	65.36	1.413	0.9851	0.0149	347.285	0.111
F4	54.50	57.07	1.047	0.9870	0.0130	320.045	0.056
F5	23.50	28.58	1.216	0.9935	0.0065	114.570	0.021
F6	32.50	37.32	1.148	0.9915	0.0085	198.085	0.058
F7	30.75	38.48	1.251	0.9912	0.0088	201.920	0.059
F8	28.00	58.83	2.260	0.9856	0.0144	275.510	0.066
System	33.34	46.83	1.4045	0.9893	0.0107	1658.180	0.061

TABLE X
RELIABILITY INDICES RESULTED FROM SEGMENTING EACH FEEDER INTO SIX PARTS

Feeders	SAIFI	SAIDI	CAIDI	ASAI	ASUI	ENS(MWh.)	AENS
F1	28.00	41.16	1.470	0.9953	0.0047	38.090	19,021
F2	13.00	31.435	2.420	0.9964	0.0036	108.45	0.044
F3	30.83	43.576	1.413	0.9950	0.0050	223.59	0.073
F4	36.33	38.046	1.047	0.9957	0.0043	213.36	0.066
F5	15.67	19.056	1.216	0.9978	0.0022	76.37	0.023
F6	21.67	24.883	1.148	0.9972	0.0028	132.05	0.023
F7	20.50	25.656	1.251	0.9971	0.0029	129.56	0.025
F8	18.67	39.222	2.260	0.9952	0.0048	183.67	0.044
System	22.27	31.274	1.4045	0.9964	0.0036	1105.14	0.041

From table V, the ENS (MWh) and Cost of energy not supplied (Birr) was calculated for the existing system by using

single month data; it is also calculated for the redesigned system as shown in Table XI.

TABLE XI
COMPARISON OF EXISTING AND REDESIGNED SYSTEM FOR ENS AND COST OF ENERGY NOT SUPPLY FOR SINGLE MONTH

Feeders	ENS (MWh)					Cost of energy not supplied (CENS) in (Birr)				
	Existing system	Redesigned system				Existing system	Redesigned system			
		Two segment	Three segment	Four segment	Six segment		Two segment	Three segment	Four segment	Six segment
F1	37.1795	18.589	-	-	-	19,872.44	9,936.22	-	-	-
F2	140.4600	70.230	47.321	35.691	23.41	75,075.87	37,537.92	25,293.053	19,076.77	12,512.65
F3	308.6250	154.312	103.975	99.578	51.44	164,960.06	82,480.03	55,575.044	41,916.35	27,494.68
F4	514.0985	257.049	173.199	130.632	85.68	274,785.65	137,392.8	92,575.285	69,823.03	45,795.96
F5	137.2555	68.627	46.241	35.876	22.88	73,363.06	36,181.53	24,716.015	18,641.55	12,229.36
F6	491.9030	245.951	165.722	124.992	81.98	262,922.15	131,461.1	88,578.472	66,808.52	43,818.31
F7	361.4914	180.745	121.786	91.854	60.25	193,217.15	96,608.57	65,094.857	49,096.48	32,203.63
F8	255.7915	127.895	86.176	64.996	42.63	136,720.56	68,360.28	46,061.156	34,740.69	22,641.42
Total	2,246.80	1,123.4	759.948	570.913	374.47	1,200,916.9	600,458.4	404,588.90	305,152.98	200,154.22

The gross average energy not supplied and the average energy expense not supplied due to a one-month power interruption in the current Cotebie outgoing feeders is 2,246.8MWh and 1,200,916.9 birr, respectively, from Table XI. For the outgoing feeders of the substation, the overall average cost of

energy not generated due to power interruption per year is $12 \times 1200916.95 = 14.411$ million Birr. However for the revamped Cotebie outgoing feeders, the total average energy not supplied and the average cost of energy not supplied due to a one-month power interruption was planned in two, three,

four and six section cases of 1,123.4MWh, 759.948MWh, 570.913MWh and 374.47MWh ENS and 600,458.4birr, 404,588.9birr, 305,152.98birr and 200,154.22 birr CENS, respectively. For the outgoing feeders of the substation for two, three, four, and six-segment situations, the gross average cost of energy not supplied due to power interruption per year is

$12 \times 600,458.4 = 7,205,500.8$ birr/year, $12 \times 404,588.9 = 4,855,066.8$ birr/year, $12 \times 305,152.98 = 3,661,835.76$ birr/year, and $12 \times 200,154.22 = 2,401,850.64$ birr/year respectively.

The sample simulation results of the system with six segments are shown in figure 3 below.

Predictive Reliability Analysis Settings
Source:

Database: C:\MILSOFT\DATABASE\SEA.WM\
Title:
Case: 11/03/2019 01:31

Reliability Analysis Settings:
Do Upline Fault Isolation
Do Downline Fault Isolation
Include Coordination Failure
If Fix Time is less than 1.00 hours then do not consider switching.
Do switching only if outage hour improvement is greater than 30.00 percent.
1 Crew is available to work each outage.
Time to find trouble is 1.00 hours.
Travel Time is fixed at 0.17 hours per trip.
If calculated travel distance is less than 0.25 miles then travel time is set to 0.0 hours.

Source Name	SAIFI	SAIDI	CAIDI	ASAI	ALIFI	ALIDI	Consumers	KVA
F4	36.3333	38.0458	1.0471	0.9957	36.3333	38.0458	3240.0	5608.0
F5	15.6660	19.0499	1.2160	0.9978	15.6660	19.0499	3358.0	4008.0
F1	28.0000	41.1600	1.4700	0.9953	28.0000	41.1600	2.0	925.0
F6	21.6667	24.8733	1.1480	0.9972	21.6667	24.8733	5686.0	5307.0
F7	20.5002	25.6458	1.2510	0.9971	20.5002	25.6458	5225.0	5050.0
F8	18.6667	42.1867	2.2600	0.9952	18.6667	42.1867	4167.0	4683.0
F2	13.0020	31.4648	2.4200	0.9964	13.0020	31.4648	2476.0	3450.0
F3	31.1664	44.0381	1.4130	0.9950	31.1664	44.0381	3052.0	5313.0
Total System	22.2668	31.2744	1.4045	0.9964	23.5505	32.8846	27206.0	34344.0

Figure 3: Simulation Report of the Design by Segmenting Each Feeder into Six Parts

B. Comparison of the existing and redesigned system

- The SAIFI value of the redesigned system is reduced from 133.36 int./yr./cust in to 66.7, 44.45, 33.34 int./yr./cust, and 22.27 int./yr./cust for four different segment cases with two, three, four, and six reclosers, respectively. It is reduced by 50%, 66.67%, 75%, and 83.3% for four segments, respectively.
- The SAIDI value of the redesigned system is reduced from 187.31 hr./yr./cust into 93.656, 62.44, 46.83 hr./yr./cust, and 31.274 hr./yr./cust for four different cases with two, three, four, and six reclosers, respectively. It is reduced by 50%, 66.67%, 75%, and 83.3% for four cases, respectively.
- ENS of the overall system of the existing system was 6,526.168 MWh. The redesigned system ENS value is 3263.08, 2198.22, 1658.18 and 1105.14 for segment two, three, four, and six-segment cases, respectively. And improved by 50%, 66.1%, 74.47%, and 83.066% respectively.
- The total average cost of energy not supplied because of power interruption per year for the substation's outgoing feeders is 14.411 million Birr. But the total average cost of energy provided not because of power interruption per year for the substation's outgoing feeders for two, three, four, and six-segment cases are 7,205,500.8 birr/year, 4,855,066.8 birr/year, 3,661,835.76 birr/year, and 2,401,850.64 birr/year, respectively (See table XI).
- AENS of the overall system of the existing system was 0.239. The redesigned system AENS values 0.120, 0.081, 0.061, and 0.041 for two, three, four and six-

segment cases, respectively. And improved by 50%, 66.1%, 74.47%, and 82.84% respectively.

The existing system is analyzed by three methods which are an analytical method, by DlgSILENT and Windmill software.

But the result is almost similar. Two methods calculated the redesigned system by using the analytical method and Windmill software, it is also similar. The overall system reliability indices comparisons of existing and redesigned systems are shown in Table XII.

TABLE XII
COMPARISON OF THE EXISTING AND REDESIGNED SYSTEM

		SAIFI	SAIDI	CAIDI	ASAI	ASUI	ENS	AENS
Existing System		133.37	187.3104	1.4045	0.9786	0.0214	6526.168	0.239
Redesigned System	Two segment	66.70	93.6560	1.4045	0.9893	0.0107	3263.080	0.120
	Three segment	44.45	62.4400	1.4045	0.9929	0.0071	2198.220	0.081
	Four segment	33.34	46.8300	1.4045	0.9893	0.0107	1658.180	0.061
	Six segment	22.27	31.274	1.4045	0.9964	0.0036	1105.14	0.041

VIII. CONCLUSION

The Coterie distribution network's reliability analysis is calculated using an analytical method and simulated by Windmill software. Its reliability does not meet the standards set by the Ethiopian Electrical Agency's (EEA's). The average frequency of interruption is 133.37 interruptions per year per customer and the average interruption duration is 187.31 hours per year per customer. Generally, based on reliability indices values, Cotebie distribution power supply is unreliable. Therefore, a smart grid can be used to solve the problems of the existing power grid. The overall system's reliability can be improved using key components of smart grid or protection devices such as smart reclosers and disconnectors. The average frequency interruptions and interruption durations are improved by 50%, 66.67%, 75%, and 83.3% for four different cases, respectively. The cost of unsold energy also reduced from 14,411,000 birr/ year in to 7,205,500.8birr/year, 4,855,066.8birr/year, 3,661,835.76birr/year, and 2,401,850.64birr/year four different cases respectively.

For upgrading the Cotebie distribution system with protection devices, 48 reclosers and 50 disconnectors are used to achieve 83.3% reliability improvement. The investment cost includes the total cost of recloser, total cost of disconnector, Maintenance cost, installation cost amounts to 680,458.522USD and the average saved revenue by the utility 83.3%reliability improvement is estimated to be 406,126.12USD per year. Hence, the payback period is estimated to be about 1 year and eight months, which indicates the idea's economic viability.

IX. RECOMMENDATION AND FUTURE WORK

Base on the thesis work the following recommendations are drawn

- The radial nature of the distribution network also increases reliability problems, converting the system in to ring for high priority customers.
- EEA has to exert more control over EEU performance, either by scheduling maintenance tasks for the system components or imposing performance-based tariffs instead of standard energy-based tariffs. Then, the primary objective for EEU is to achieve the benchmarks imposed by EEA while meeting budget constraints.
- We are giving attention to preventive maintenance to improve random power interruptions, the sustainability of equipment, and deliver reliable power to the customer.
- Smart grid integration with renewable energy sources such as wind and solar power, and Smart grid integration with back-up distribution generators and advanced energy storage systems.

REFERENCES

- [1]. Skoonpong, A., & Sirisumrannukul, S. (2008, May). Network reconfiguration for reliability worth enhancement in distribution systems by simulated annealing. In *2008 5th International Conference on Electrical Engineering/Electronics, Computer, Telecommunications and Information Technology* (Vol. 2, pp. 937-940). IEEE.
- [2]. Vrana, T. K., & Johansson, E. (2011). Overview of power system reliability assessment techniques. *CIGRE 2011*, 51-62.

- [3]. Alekhya, K., Murthy, P. S. R., & Bhargava, C. (2011). Assessment of Reliability for Distribution Feeders on the Basis of Cost Analysis. *Bonfring International Journal of Power Systems and Integrated Circuits, 1*(Special Issue Inaugural Special Issue), 15-19.
- [4]. Bowen Hua, Haipeng Xie, Yongkai Zhang and Zhaohong Bie, Reliability Evaluation of Distribution Systems by Considering Demand Response. *School of Electrical Engineering, Xi'an Jiaotong University Application of IEEE Std 1366™*, 2012.
- [5]. Manandhar, S. (2013). Reliability assessment of smart distribution system and analysis of automatic line switches.
- [6]. Reddy, S. C., Prasad, P. V. N., & Laxmi, A. J. Reliability Improvement of Distribution System: A Hybrid Approach Based on GA and NN.
- [7]. Ashok, V., Harikrishna, K. V., Chandrasheksr, P., & Raghunatha, T. (2013). Performance Assessment in Power Distribution System Based on Reliability Indices. *ICPES, Kaulampur-Malaysia*.
- [8]. Kovač, Z., Knežević, G., & Danijel, T. (2013). MODELING OF POWER SYSTEM RELIABILITY ASSESSMENT. *Tehnicki Vjesnik-Technical Gazette, 20*(1), 93.
- [9]. Gao, L., Zhou, Y., Li, C., & Huo, L. (2014). Reliability assesment of distribution systems with distributed generation based on Bayesian networks. *Engineering Review: Međunarodni časopis namijenjen publiciranju originalnih istraživanja s aspekta analize konstrukcija, materijala i novih tehnologija u području strojarstva, brodogradnje, temeljnih tehničkih znanosti, elektrotehnike, računarstva i građevinarstva, 34*(1), 55-62.
- [10]. Rashid Niaz Azari, Mohammad Amin Chitsazan, Iman Niazazari. Optimal Recloser Setting for Considering Reliability and Power Quality in Distribution Network, *American Journal of Electrical Power and Energy Systems*, Vol. 6, No. 1, 2017, pp. 1-6.
- [11]. Bill Glennon, Christina Kusch, and Elijah Nelson. Improve Reliability and Power Quality on Any System, Schweitzer Engineering Laboratories, Inc, Buenos Aires, Argentina ,September 24–26, 2018
- [12]. Phyu, E. E., Lin, K. M., & Moe, T. T. (2018). Loss Reduction and Reliability Improvement of Industrial Distribution System through Network Reconfiguration. *International Journal of Energy and Power Engineering, 12*(11), 807-813.
- [13]. Anthony, R. (2014). *Reliability analysis of distribution network* (Doctoral dissertation, Universiti Tun Hussein Onn Malaysia).
- [14]. Kaduru, R., & Gondlala, N. S. (2015). Distribution System Reliability with Distributed Generation Based on Customer Scattering. *Advances in Electrical and Electronic Engineering, 13*(2), 64-73.
- [15]. Branch, H. (2016). Optimum network reconfiguration to improve power quality and reliability in distribution system. *International Journal of Grid and Distributed Computing, 9*(4), 101-110.
- [16]. Eminoglu, U., & Uyan, R. (2016). Reliability Analyses of Electrical Distribution System: A Case Study. *International Refereed Journal of Engineering and Science, 5*(12), 94-102.
- [17]. Emjedi, M. R., Awodele, K., Chowdhury, S., & Chowdhury, S. P. (2010, July). Reliability evaluation of distribution networks using fuzzy logic. In *IEEE PES General Meeting* (pp. 1-8). IEEE.
- [18]. Rouse, G., & Kelly, J. (2011). Electricity reliability: Problems progress and policy solutions. *Galvin electricity initiative, 28*, 17-20.
- [19]. Hendi, R. B., Seyed-Sheneva, J., & Gandomkar, M. (2012). Electrical distribution system reliability improvement by optimal placement of fault indicators using immune algorithm. *Int. J. Eng. Res. Applicat.(IJERA), 2*(2), 1383-1390.
- [20]. Hegvik, A. (2012). *Case Study Analysis of Running Distributed Generators in Island Mode: Effects on Reliability of Supply* (Master's thesis, Institutt for elkraftteknikk).